

Adolescent Diary Weblogs and the Unseen Audience

Lois Ann Scheidt

Introduction

In their latest model of blog populations, Perseus Development Corporation estimates that as many as 31.6 million weblogs “have been created on services such as BlogSpot, LiveJournal, Xanga and MSN Spaces, with 10 million created in the first quarter of 2005 alone” (Henning, 2005). Their previous study found that up to 66% of the blogs have been either temporarily or permanently abandoned (Henning, 2003). Therefore, 31.6 million is both an underestimate of the population of blogs available online—as there is no reliable count of blogs available outside of the hosted sites—and an overestimate—as there is no accounting for inactive blogs, since as many as 20.8 million of the blogs included in their study may be abandoned, potentially leaving 10.7 million active sites on the listed hosts.

The growing presence of weblogs in online communication has led to increased academic scrutiny. Previous research has considered the genre of weblogs (Herring, Scheidt, Bonus, & Wright, 2004b), political weblogs (Cherry, 2003), weblogs as journalism (Gallo, 2004), and weblogs as community (Blanchard, 2004; Wei, 2004). In our work on genre, the Blog Research on Genre Project (Herring et al., 2004b) found that diary weblogs, particularly those produced by adolescent bloggers (Herring, Kouper, Scheidt, & Wright, 2004a; Herring et al., 2004b), were the most numerous type. While a special issue of *Biography: An Interdisciplinary Quarterly* titled “Online Lives” (vol. 26, no. 1, Winter 2003) presented academic studies outlining the transition of diary and autobiography to online spaces such as weblogs (Mcneill, 2003), little academic interest

has been drawn to adolescent use of these spaces (cf. Herring et al., 2004a; Huffaker, 2004).

In all of these genres, the formal audience, rather than being defined by the communication media, is a construct of the discursive practices utilized, and is embedded into the narrative through the author's choices during production (Anderson, 1996: 78). Likewise Bloom (1996) suggests that diary authors may have many implied audiences in mind as they construct their written work – children, spouses – as well as a larger generalized audience of strangers.

This paper first situates adolescent diary weblogs and their implied audiences and then applies a typology of audiences for personal narrative performance to a sample of diary weblog posts to ascertain if the typology fits the implied audiences present in the weblog text.

Background

Weblogs

Weblogs, aka blogs, have been defined as “frequently modified web pages in which dated entries are listed in reverse chronological sequence” (Herring et al., 2004b).

A more specific definition is that given by Todd Stuffer in his book *Blog On: The Essential Guide to Building Dynamic Weblogs*:

A weblog or blog is a website that's designed to be updated with items in a linear, time-based fashion, similar to a personal journal or diary, except that the contents are meant specifically for public consumption. Often implemented using special software, weblogs contain articles or entries that are grouped primarily by the date and time they are posted. (2002: 4)

However, while some weblogs are meant for public consumption and are therefore available to any viewer, many other websites that could legitimately be classified as weblogs are available only to those who have been granted access through such techniques as passwording on diary weblogs or intranet-only access for k-logs. Therefore, modification of Stauffer's definition is necessary and the following will be used in this paper: A weblog is a frequently modified website that allows updating with items that are grouped primarily by the time and/or date of posting. Entries usually appear in reverse chronological order. Contents of the weblog may be available publicly or through restricted access. Weblogs may also utilize special software designed for this implementation.

In "Bridging the Gap: A Genre Analysis of Weblogs," Herring et al. (2004b) identify five genres of weblogs:

- Filter - potentially the oldest form of weblog, with some tracing the roots of the genre to Tim Berners-Lee (1992), who posted a list of links to all the new websites as they came online (Winer, 2002). A filter weblog have content that is external to the weblogger, such as national and international events (Blood, 2002).
- Diary or personal journal weblogs – diary weblogs have content such as the bloggers personal thoughts and feelings (Blood, 2002).
- K-log - Knowledge-logs are weblogs that have been created as repositories for knowledge sharing (Festa, 2003). An example of this category would be *a klog apart: Phil Wolff's subversions...* (<http://dijest.com/aka/>).
- Mixed purpose - Combine the functions of two or more genres -- diary/personal journal weblogs, k-logs, or filter weblogs (Herring et al., 2004b).

- Other - Served miscellaneous functions not accounted for in the four preceding categories (Herring et al., 2004b). These functions included acting as a repository for song popular lyrics.

In our study of a random sample of publicly available English language weblogs, we found that 70.4% of the sample met the definition of diary blogs (Herring et al., 2004b). As the largest genre of weblogs, diary weblogs are a locus for life-writing (Mcneill, 2003). Diary weblogs bear a resemblance to their paper-based antecedents in that they are usually written by a single author (Fothergill, 1974) in first person (Mcneill, 2003). They tell an episodic story (Walker, 2003) that may be fragmentary (Hogan, 1991) and is always in process (Culley, 1985). The continuation is open-ended and terminates when the writer ceases to make entries (Bunkers, 2001).

Two time-worn assumptions of paper diaries fall away when looking at diary weblogs. First, the view that diaries are kept only for the personal consumption of the author (Mcneill, 2003: 26) is unsuitable when the diary is posted online. Second, the view that diary keeping is a private and secret effort (Bunkers, 2001; Lejeune, 2001) is out of place when the diary is available for public access. In online forums these views converge to create what Kitmann calls “connected privacy” (2004: 91), a place where connections between persons and communities exist but these connects have permeable boundaries allowing access and interaction to persons outside the basic connection set. Yet within these insecure boundaries privacy is possible.

The uniqueness of weblogs comes from their ability to blend personal narrative with performance characteristics, like stage settings, through the use of color and image and interaction with the audience by way of reciprocal discussion in comments, posts,

and via communication lines outside the weblog space using channels such as email and instant messaging. These channels are controlled by the author and limited only by the technology and the author's capability to use the technology. While these characteristics can be found in webpages as well, the frequent updating that defines weblogs provides for a higher level of performance and interactivity.

Adolescents

With the rapid growth of weblogs has come increased academic interest, marked by scholarly publications such as *Into the Blogosphere* (Gurak, Antonijevic, Johnson, Ratliff, & Reyman, 2004) and dedicated conferences such as *Blogtalk* (<http://www.blogtalk.net/>). However, published research has focused primarily on adult users while marginalizing the activities of adolescent bloggers (Herring et al., 2004a). This limited research under-represents adolescents' presence online, despite the fact that an estimated 73% of American teenagers ages 12 through 17 use the Internet (Lenhart, Rainie, & Lewis, 2001). Likewise, the "UK Children Go Online" study found that 92% of the 9-19 year olds interviewed had access to the internet at school, while 75% had access from home (Livingstone & Bober, 2004).

Many adolescents and young adults have adopted weblogs as a communication venue. Henning's (2003) finding that 92.4% of weblogs are produced by authors under 30 years of age positions weblogs as the province of adolescents and young adults. We have found that between 34.3% (Herring et al., 2004b) and 38% (Herring et al., 2004a) of weblogs were written by adolescents, with diary weblogs the predominant genre

produced (Herring et al., 2004b). Orlowski (2003) goes further, asserting that a majority of bloggers are teenage girls.

Like homepages before them, weblogs are prominent venues for adolescents to present themselves in textual and multimedia fashion. Weblogs give adolescents the opportunity to “exercise their voices in personal, informal ways, and indirectly promote digital fluency” (Huffaker, 2004). Authors of weblogs, like authors of webpages, use the space to communicate their desire to reach an audience (Stern, 2004).

In American culture, adolescence has been seen as a liminal period (Turner, 1982): the adolescent is not exactly a child and not exactly adult. This period is seen to end abruptly on the 18th birthday when a teen is accepted as a “legal adult.” As can be observed from the academic works cited in this paper, the definitions of adolescent, teen, and youth have been applied quite flexibly to identify individuals ranging in age from 9 to 21. The new category of “emerging adulthood,” ages 18-25 (Arnett, 2000), is also gaining currency as it encompasses and extends the transitional years. For this paper, I have adopted the Steinberg (2002) definition of adolescence as the second decade of life, ages 10-19. This definition creates an easily understandable age range that can be viewed similarly across projects.

Once a term such as adolescence is defined in a research project, the next question is, what data do we collect to measure the variable? There is an active concern among parents and their children who use online spaces (Livingstone & Bober, 2003: 24) that adults pretending to be children and adolescents are present in internet venues. There has not been academic scrutiny of the issue; however, there has been previous discussion in academic writing related to the phenomena of participants in online forums masquerading

as an other gender (Danet, 1998; LaPin, 1998; Reid, 1994; Reid, 1991). In looking at these two points, it is clear that the same issue is present in both discussions – the ease with which alternative identities can be created online bears little resemblance to ones offline life (Donath, 1999).

Within an online space, accurate determination of participant identity characteristics is difficult but not impossible. For this research, determination of the weblog author's proper classification as an "adolescent" is made through triangulation. First, a thorough examination of any direct references to the participant's age is conducted, e.g., in the post text or in the profile. Then a careful reading of the weblog posts is done with special emphasis on topics, e.g., school, after-school jobs, sports, and dating. Consideration is also made of language structure and use, e.g., is it consistent with the stated or apparent age of the author? Finally, where there are no strong reasons to doubt the author's veracity, age is accepted on face value.

Adolescents may be particularly drawn to diary weblogs because of their growing self-consciousness and self-awareness (Steinberg, 2002). During adolescence individuals may have the egocentric feeling that they are always being watched by an imaginary audience (Elkind, 1967), the imaginary audience and personal fables may remain in place throughout the lifespan (Goosens, Seiffge-Krenke, & Marcoen, 1992). "The imaginary audience involves having such a heightened sense of self-consciousness that the teenager imagines that his or her behavior is the focus of everyone else's concern" (Steinberg, 2002: 63). Likewise, the adolescent may develop personal fables around the belief that their experiences are unique (Steinberg, 2002: 63). Both of these developmental concepts

may push adolescents to perform their personal fables in diary weblogs for the audience they believe is already interested in watching them.

Audience

When we think of an audience, our concept is marked by a historical view of collocation where individuals come together to “create the motive and the site for public presentation” (Anderson, 1996: 75). The implied connectivity of the audience through collocation has been broken as technological advancements have allowed communication portability. Walter Ong (1982) points out that the term “audience” has been extended to include groups of readers as a collective. Likewise, the expansion of this definition has been made to include dispersed audiences for television (Bird, 2003; Brooker & Jermyn, 2003; Hay, Grossberg, & Wartella, 1996) and the internet (Hine, 2001; McLaughlin, Goldberg, Ellison, & Lucas, 1999).

Online communication goes beyond the limitations of these primarily textual narrative environments. Cho (in press), in her study of email and memoranda, found that electronic communication exhibits characteristics of both written and informal oral communication. In much the same way, Langellier and Peterson (2004) point to weblogs as “sort of like” conversation with an approximation of audience feedback. Both of these articles set up a continuum with historically familiar forms of communication – memoranda, performance, etc. – as exemplars, then position new communication media as somewhat less than the exemplar.

As can be seen through this discussion, diary weblog entries bear some resemblance to personal performance narrative. The application of Langellier’s typology

to diary weblogs will extend the current understanding of the audiences embedded within and addressed through diary weblog posts.

Langellier's Typology of Audience

In her addition to Sheron J. Dailey's edited volume *The Future of Performance Studies: Visions and Revisions* entitled "Voiceless bodies, bodiless voices: The future of personal narrative performance," Kristin Langellier (1998: 210) presents five types of audience for personal narrative performance. In this typology, the audience is asked to act as a: Witness testifying to the experience; Therapist unconditionally supporting emotions; Cultural theorist assessing the contestation of meanings, values, and identities in the performance; Narrative analyst examining genre, truth or strategy; and Critic appraising the display of performance knowledge and skill.

Following are examples of each of Langellier's audience types. As Langellier does not include narrative definitions of each audience type, I have used her titling as a jumping off point in developing the codebook for this project. Each example includes a screenshot of the weblog that will be used in illustration. With the illustration is the text entry, in part or in whole, of a weblog post that exemplifies the category of audience. Weblog text examples will begin with <snip> and end with </snip>. Text examples are presented verbatim including misspellings, emoticons, irregular capitalizations, bold and italics, etc. I have, however, excluded in-text embedded links and the associated underlining as they are outside the preview of this chapter.

As a witness testifying to the experience

This audience category is the most general of the five and is the type of audience most people expect to be part of when observing a performance. In these personal experience narratives the author presents a story of an experience from the past (Denzin, 2001: 61), asking the audience to observe the experience framed for them by the author. The narrative for this type of entry is usually presented in a linear fashion, including transitions such as “after that we/I” and “then we/I”.



Figure 1 - Available: <http://16cravons.blogspot.com/>

<snip> So, I went to Dorney Park yesterday. Happy, happy, joy, joy. It wasn't all that bad, actually. I woke up an hour late because I set my alarm for seven p.m. instead of seven a.m., but nevertheless my Dad woke me up at eight. So I hoped in the shower and ran around in order to pick up Vickie and get to the art studio. I put on my new Good Charlotte shirt, so when I got to the studio there was **NO WAY** I was going to paint. ... Anyway, after I was finished at the studio my family and I were off to Dorney Park.

</snip>

In this entry the author takes the audience step by step through her day from arising in the morning through her time spent with her family at the water park. She tells the audience the story, asking them to become part of the experiences though her description of her activities. The text of her post uses long sentences with simple words and containing extensive detail. The narrator relays the story in first-person major character by placing herself in the center of the story through the extensive use of “I”.

As a therapist unconditionally supporting emotions

In this category, the authors consciously or unconsciously ask the audience to validate and unconditionally support their emotional positions. Tone is a primary indicator of this type of post.

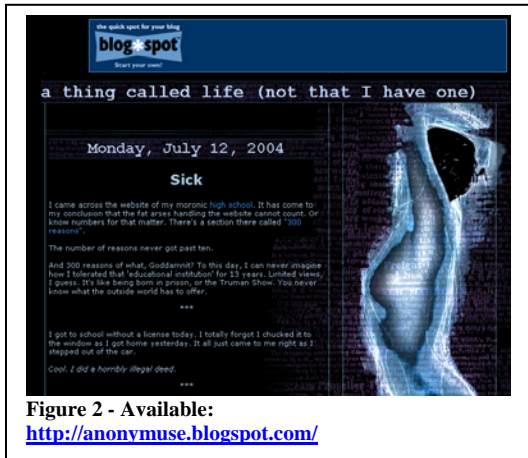

Figure 2 - Available:
<http://anonymuse.blogspot.com/>

<snip>The inevitable has taken place. I have once again stepped within the walls of an institution frequented by asylum-deprived eccentrics and egocentrics. But I love it.

No longer a freshie... This cannot be happening. No more excuses to be ignorant.

No more innocent eyes. No more fun

classes...*sniff*

But enough of that. The new freshies are here. Gotta show them who's boss. They're easy to spot. They usually go in herds, eagerly sticking to everyone so as not to get lost.

Reminds me during freshie, first sem reg, EVERYone spoke to each other in english, hoping not to give themselves away as tagalog-speaking regular students. But of course that only lasted a few days. A week max. Then everyone discovered the joys and comfort of speaking their own tongue (blogging is a different story, dear).

Anywhoo, you should've seen the freshies today. So scared to stay away from each other with the fear of becoming the block outcast. tsk tsk. It's been a year, God damn it. A frekkin year. Pathetic. A college sophomore yet already filled with nostalgia. Wait till I turn 35. </snip>

In this post, the author asks the audience to validate her experience as a new freshman and support that she has gone beyond what she now views as immaturity and inexperience. Now she is a sophomore, nostalgic and accepting that she can fit in the college environment. In this post the narrator fluctuates between first-person major character and second-person point of view (Yordon, 1999), the transition is marked by the change in focus from “I” to “you” thereby directly addressing the audience and inviting them into the story. She tells us this using short sentences with complex words and textual actions, i.e. *sniff*.

As a cultural theorist assessing the contestation of meanings, values, and identities in the performance

In this category, the audience is asked to apply their understanding of the bloggers and their own cultures in evaluating values; beliefs; meanings; and identities, including race, social class, and gender issues described in the post.



Figure 3 – Available <http://coquet.blogspot.com/>

<snip>things that piss me off: no.
 1...anti-bush protestors
 i live in the uk, and upon george bush's recent state visit here, hundreds o' thousands of people went out into the streets protesting at his visit, calling him "the most evil man on the planet" and so on...

where the hell were these protestors during all the years of oppression that the iraqi people faced? probably eating mcdonalds and driving ford cars to work

why do these people not protest against E.U farming subsidies, which un-deniably contribute to poverty amongst african/asian farmers? possibly because they are too busy watching the latest episode of neighbours (oh my god! steph has cancer! she had better pull through...max and the kids deserve better!) </snip>

In this post the author asks the audience to share his cultural and personal values in assessing issues of belief and social class. He presents a comparison of political protestors in Britain turning out in large numbers to protest the United State's President George W. Bush's visit to the smaller number of protestors who appear in the street to picket against European Union farm subsidies, an issue the author sees as more important. The text of his post is presented without the standard capitalization found in formal English sentences. The narrator tells us the story from the first-person major character perspective but also invites us into the performance by the use of questions to call forth the authors point of view. Though unlike the standard first-person major narrator he utilizes limited omniscience in telling us what other values the protestors hold more highly - "eating at mcdonalds" and "watching the latest episode of neighbours" - then concern for groups of disenfranchised persons - "iraqi people" and farmers.

As a narrative analyst examining genre, truth or strategy

In this category, the author asks the audience to examine the production of narrative. This category may include meta-discussions of weblog narrative, as well as other online or offline narratives. Posts may include references to real or imagined audience reactions to the narrative.

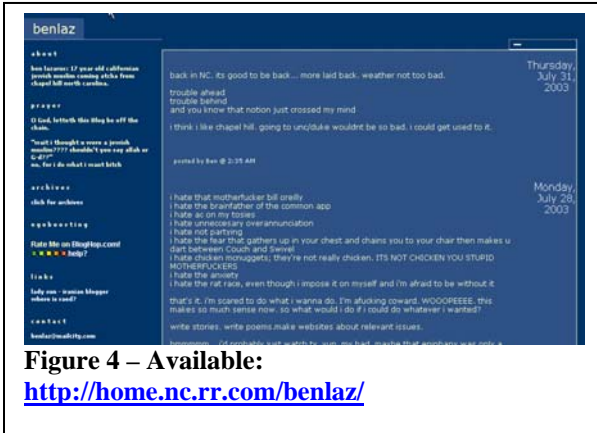

Figure 4 – Available:
<http://home.nc.rr.com/benlaz/>

<snip>i have to start thinking about applying to college. not that i havent been doing that for the last two years, but now i have to start acutally writing my essays and applying. i should definitely talk about being muslim and

jewish and how unique and amazing and diverse and all that other fuckingshit my experience is. for some reason the thought of talking about that just makes me cringe. maybe because i havent figured all that out myself and i'm not really sure *what* i am.

for georgetown, one of the essays is 'describe an experience that describes you' or some bullshit to that effect. i really dont feel like doing that. you see, i've been really busy lately. first of all, now theyre doing that 70s show reruns ALL THE TIME. how could i miss those, right?</snip>

In this post, the author is discussing the construction of essays that must accompany his college applications. He introduces that his personal essays will address his experiences as an adolescent of mixed religious ancestry – Jewish and Muslim. He also presents the fact that discussing his ancestry is difficult, as he himself has yet to integrate the meaning and impact of both facets on his life. This entry utilizes a first-person major character narrator with transition into second-person through the use of “you see” in the last paragraph. The author uses lower case letters in many places one would expect to see upper case formal English sentence structure. Likewise he has chosen to replace commas in complex sentences with periods, or with no punctuation. This creates a somewhat mixed when reading the section.

A critic appraising the display of performance knowledge and skill

This type of weblog post asks the audience to assess the merit of the author's performance. The appraisal request may refer to performances within or outside the weblog space. Possible examples include artwork, poetry, dance or singing, song writing and lyrics.

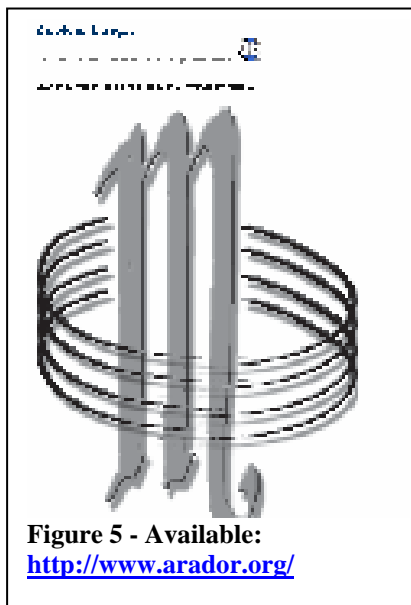

<snip>I just threw this image together, and I think it turned out nicely...</snip>

In this entry the author is displaying a new graphic design to the audience and asking for feedback on his design prowess. In this post the words are overshadowed by the much larger graphic of which the author speaks.

The interest in adolescent weblogs, bloggers, and their audiences is just beginning. This paper extends the current understanding of adolescent weblogs by applying Langellier's typology of personal narrative performance audiences to a sample of adolescent weblogs.

Methodology

This study utilizes computer-mediated discourse analysis techniques in applying content analysis and ethnographic methods to an opportunity sample (N=12) of adolescent diary weblogs.

The sample itself was drawn from the EatonWeb Portal (<http://portal.eatonweb.com>) under their Teen category (<http://portal.eatonweb.com/cat/Teen>). EatonWeb was originally a hand-coded list of all the weblogs available online (Rhodes, 2002). As the number of available weblogs increased, the site reconfigured to allow for self-submission of weblogs and keywording by the authors/submitters through a JavaScript file (Rhodes, 2002).

Each entry in the “teen” category was reviewed on April 3, 2004 to ascertain that 1) the listed website was available and met the definition of a weblog, 2) English is the weblogs primary language, and 3) the weblogger met the age criteria of the study at the time of the review. The first page of weblogs that met the criteria, were then archived for coding. All entries on the first page of the weblog were force coded for audience category and demographic data.

Discussion

In every weblog reviewed I was able to assign the authors to a sex category based on their statements in the text or in the profile. The 12 weblogs were evenly divided between female and male authors (N=6 each).

The average entries per main page were 8.5 with a range of 4 to 21. The female authors averaged fewer entries per page than the males. Females averaged 6.8 entries, ranging from 5 to 14 entries on the main page, and produced 41.6% of the entries. Males averaged 10.2 entries with a range of 4 to 21 entries and produced 58.4% of the entries in the corpus. When the outlier, responsible for 21 entries, was removed, the males averaged

eight entries per page with a range of 4 to 14, similar to the female average. Over 85% of entries reviewed were written in the first person.

The average age of the authors was 16.9 years with a range from 13 to 19 years old. Males were slightly more likely than females to have listed an age in either the text or the profile, with five males providing the information compared to four females who did so. Females were slightly older than males, with an average age of 17.8 years for females (range 15 – 19) and 16.5 for males (range 13 – 17).

The weblogger’s country of origin was explicit or implicit in every weblog reviewed. Seven of the authors were from the United States, with two each from the Philippines and Singapore, and one from the United Kingdom.

Eighty-nine posts could be fully coded, with 13 that did not meet the requirement of posts with text that appeared to have been written by the weblogger - including blank

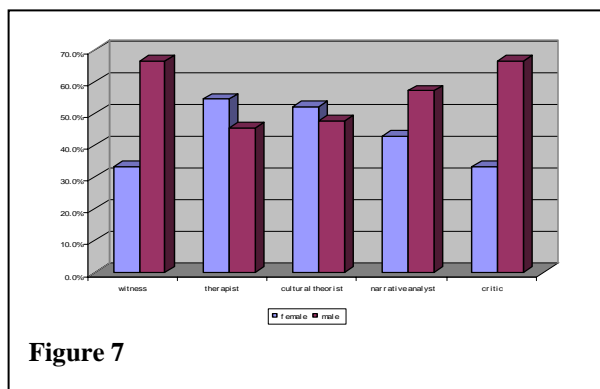

posts, picture only, and popular song lyrics.

When applying Langellier’s audience typology, I found the predominant category was audience as witness to the experience, with 50.6%

of the entries. The category with the second highest occurrence, with 25.8% of the entries, was cultural theorist assessing the contestation of meanings, values, and identities in the performance. The therapist unconditionally supporting emotions category accounted for 12.4% of the 89 posts coded. Narrative analyst examining genre, truth, or strategy audiences was sought by 7.9% of the posts. Finally, the remaining 3.4% of the

posts asked their audiences to function as critic appraising the display of performance knowledge and skill.

The type of audience was then broken down by the sex of the author. Males created more witness to the experience type posts than did females, with 66.7% produced by males compared to 33.3% for females. More entries seeking therapist audience type were created by females than males, 54.5% vs. 45.5%. Likewise, females authored more cultural theorist posts than did their male counterparts, 52.2% to 47.8%. Conversely, males (57.1%) authored more narrative analyst type posts than did females (42.9%). Finally, males also produced more critic type posts than did females, 66.7% to 33.3%.

Conclusions

It has been suggested that the diary is a feminine form of self-presentation because it often concentrates “on the everyday (for which to some extent read ‘trivial’ and ‘ephemeral’)” (Hogan, 1991: 96). While both genders produce a variety of discourses, all diaries “depict the individual in relation to truth, and the real, and identity” (Gilmore, 1994: 18). Diary weblogs, like any other locus of action and interaction, are “socially and culturally constructed and reflects ideas about how we interact within a culture and how that culture influences us” (Huff, 1996: 123).

This research underscores Friedman’s (1988: 44) point that “women often explore their sense of shared identity with other women, aspects of identity that exists in tension with a sense of their own uniqueness.” The young women whose weblogs have been analyzed herein illustrate this tension through a tendency toward seeking support for their individual struggles with appeals to the envisioned audience. While it is clear that the

individual bloggers envision a female audience, their quest for nurturance resonates with the private domain that has been associated with women (Culley, 1985: 3).

Historically within that private domain women's diaries, as a form of autobiography,

...rarely mirror the establishment history of their times. They emphasize to a much lesser extent the public aspects of their lives, the affairs of the world, or even their careers, and concentrate instead on their personal lives – domestic details, family difficulties, close friends, and especially people who influenced them. (Jelinek, 1980: 7-8)

However the female bloggers who have undertaken cultural theorist posts in their weblogs are to some extent differing from Jelinek's view. These young women are exercising their power to observe their cultures and to record their thoughts in a way that allows them both public and private moments of reflection, thereby becoming part of their reality.

Likewise, males show a somewhat similar bifurcated audience focus, from internal evaluation in posts sharing their world by asking us to witness the events and requesting comment on their personal performance, to an external evaluation through narrative analysis. Both of these views are consistent with Jelinek's comments on the autobiographies of males:

...consensus among critics is that a good autobiography not only focuses on its author but also reveals his connectedness to the rest of society: it is representative of his times, a mirror of his era. This criterion is adequately supported by the many male autobiographies which concentrate on chronicling the progress of their authors' professional or intellectual lives, usually in the affairs of the world, and their life studies are for the most part success stories. (1980: 7)

In particular the production of narrative analyst and critic appraising the display of performance knowledge and skill type posts allows the males to illustrate their

intellectual lives and prowess through their ability to conduct meta-dialogues and to produce and critique the narratives around them.

The male bloggers in this study invite the reader into their “glorification of a man, a career, a political cause, or a skillful strategy...[that] is limited almost entirely to the public sector of existence” (Gusdorf, 1980: 36). While their first-person narratives in which the audience witnesses their experiences may not be wholly limited to the “public sector,” the writers elevate the private into the public sphere by their choice to present the tale on a weblog. Likewise these formerly private narratives do not embody the same level of personal emotion found in the females appeals for support—a form that is more truly private than the often process narrative of these witness to the experience type posts.

It is clear from this research that Langellier’s typology can be successfully applied to adolescent weblogs. Such attempts at cross-disciplinary theory application are necessary during the early days of research into a new communication medium. However it should be noted that the researcher must be conscious of the effect that medium may impart on communication, so they do not fall into what Hawkens refers to as “medium blindness” (2004: 392).

Online communication media, weblogs in particular, are sites of author-audience interaction that differ from f2f performance and traditional reader relationships. Laurel makes the argument that when “the audience joins the actors on the stage,” they “become actors” rather than continuing to be an audience in their new location (2001: 110). It is clear that weblogs create loci of audience and author interaction through cross communication as well as such added enhancements as comments. While we are beginning to untangle the threads that lead to a level of co-authorship/co-audience

creation through feedback and calibration, we will someday be forced to develop new theories that transcend our old notions of implied and explicit audience.

Reference List

Anderson, James A. (1996). The pragmatics of audience in research and theory. In James Hay, Lawrence Grossberg, & Ellen Wartella (Eds.), *The Audience and Its Landscape* (pp. 75-93). Boulder CO: Westview Press.

Arnett, Jeffery Jensen (May, 2000). Emerging adulthood: A theory of development from the late teens through the twenties. *American Psychologist*, 55(5), 469-480.

Berners-Lee, Tim (1992). What's new in '92. *W3.org*. Retrieved Aug. 30, 2004 from <http://www.w3.org/History/19921103-hypertext/hypertext/WWW/News/9201.html>

Bird, S. Elizabeth (2003). *The Audience in Everyday Life: Living in a Media World*. New York: Routledge.

Blanchard, Anita Lynn (2004). Blogs as virtual communities: Identifying a sense of community in the Julie/Julia Project. In Laura J. Gurak, Smiljana Antonijevic, Laurie Johnson, Clancy Ratliff, & Jessica Reyman (Eds.), *Into the Blogosphere: Rhetoric, Community, and Culture of Weblogs*. Minneapolis: University of Minnesota. Retrieved July 2, 2004 from http://blog.lib.umn.edu/blogosphere/blogs_as_virtual.html.

Blood, Rebecca (2002). *The Weblog Handbook: Practical Advice on Creating and Maintaining Your Blog*. Cambridge MA: Perseus Publishing.

Bloom, Lynn Z. (1996). 'I write for myself and strangers': Private diaries as public documents. In Suzanne L. Bunkers & Cynthia A. Huff (Eds.), *Inscribing the Daily: Critical Essays on Women's Diaries* (pp. 23-37). Amherst: University of Massachusetts Press.

Brooker, Will & Jermyn, Deborah (2003). *The Audience Studies Reader*. London: Routledge.

Bunkers, Suzanne L. (2001). *Diaries of Girls and Women: A Midwestern American Sampler*. Madison WI: University of Wisconsin Press.

Cherry, S. M. (2003). The blog of war. *IEEE Spectrum*, 40(6), 48.

Cho, Natasha (in press). Linguistic features of electronic mail. In Herring, Susan C., *Computer-Mediated Conversation*. Cresskill, NJ: Hampton Press

Culley, Margo (1985). *A Day at a Time: The Diary Literature of American Women from 1764 to Present*. New York: The Feminist Press at the City University of New York.

Danet, Brenda (1998). Text as mask: Gender, play, and performance on the net. In Steven G. Jones (Ed.), *Cyberspace 2.0: Revisiting Computer-Mediated Communication and Community* (pp. 129-158). Thousand Oaks CA: Sage Publications. <http://atar.mscc.huji.ac.il/~msdanet/mask.html>.

Denzin, Norman K. (2001). *Interpretive Interactionism*. (2nd ed.) Thousand Oaks CA: Sage Publications.

Donath, Judith (1999). Identity and deception in the virtual community. In Marc A. Smith & Peter Kollock (Eds.), *Communities in Cyberspace* (pp. 29-59). London: Routledge.

Elkind, David (1967). Egocentrism in adolescence. *Child Development*, 38, 1025-1034

Festa, Paul (Feb. 25, 2003). Blogging comes to Harvard. *CNET News.com*. Retrieved Feb. 25, 2003 from http://news.com.com/2008-1082-985714.html?tag=fd_nc_1.

Fothergill, Robert (1974). *Private Chronicles: A Study of English Diaries*. London: Oxford University Press.

Friedman, Susan Stanford (1988). Women's autobiographical selves: Theory and practice. In Shari Benstock (Ed.), *The Private Self: Theory and Practice of Women's Autobiographical Writings* (pp. 34-62). Chapel Hill: University of North Carolina Press.

Gallo, Justin (2004). Weblog journalism: Between infiltration and integration. In Laura J. Gurak, Smiljana Antonijevic, Laurie Johnson, Clancy Ratliff, & Jessica Reyman (Eds.), *Into the Blogosphere: Rhetoric, Community, and Culture of Weblogs* (. Minneapolis: University of Minnesota. Retrieved July 2, 2004 from http://blog.lib.umn.edu/blogosphere/weblog_journalism.html.

Gilmore, Leigh (1994). The mark of autobiography: Postmodernism, autobiography, and genre. In Kathleen Ashley, Leigh Gilmore, & Gerald Peters (Eds.), *Autobiography & Postmodernism* (pp. 3-20). Amherst MA: The University of Massachusetts Press.

Goosens, L, Seiffge-Krenke, I., & Marcoen, A. (1992). The many faces of adolescent egocentrism: Two European replications. *Journal of Adolescent Research*, 7, 43-58

Gurak, Laura J., Antonijevic, Smiljana, Johnson, Laurie, Ratliff, Clancy, & Reyman, Jessica, Eds. (2004). *Into the Blogosphere: Rhetoric, Community, and Culture of Weblogs*. Minneapolis: University of Minnesota. Retrieved Aug. 25, 2004 from <http://blog.lib.umn.edu/blogosphere/>.

Gusdorf, Gustave (1980). Conditions and limits of autobiography. In James Olney (Ed.), *Autobiography: Essays Theoretical and Critical* (pp. 28-48). Princeton: Princeton University Press.

Hawken, Liv (2004). Code: Textual theory and blind spots in media studies. In Marie-Laure Ryan (Ed.), *Narrative across Media: The Languages of Storytelling* (pp. 391-404). Lincoln NE: University of Nebraska Press.

Hay, James, Grossberg, Lawrence, & Wartella, Ellen (1996). *The Audience and Its Landscape*. Boulder CO: Westview Press.

Henning, Jeffrey (2003). The Blogging Iceberg - Of 4.12 Million Hosted Weblogs, Most Little Seen, Quickly Abandoned. *Perseus Development Corporation White Papers*. Retrieved Oct. 4, 2003 from <http://www.perseus.com/blogsurvey/>.

Henning, Jeffrey (Apr. 12, 2005). The Blogging Geyser. *Perseus Development Corporation White Papers*. Retrieved Apr. 13, 2005 from <http://www.perseus.com/blogsurvey/geyser.html>.

Herring, Susan C., Kouper, Inna, Scheidt, Lois Ann, & Wright, Elijah (2004a). Women and Children Last: The Discourse Construction of Weblogs. In Laura J. Gurak, Smiljana Antonijevic, Laurie Johnson, Clancy Ratliff, & Jessica Reyman (Eds.), *Into the Blogosphere: Rhetoric, Community, and Culture of Weblogs*. Minneapolis: University of Minnesota. Retrieved July 2, 2004a from http://blog.lib.umn.edu/blogosphere/women_and_children.html.

Herring, Susan C., Scheidt, Lois Ann, Bonus, Sabrina, & Wright, Elijah (Jan., 2004b). Bridging the Gap: A Genre Analysis of Weblogs. In *Proceedings of the Thirty-seventh Hawaii International Conference on System Sciences (HICSS-37)*. Los Alamitos: IEEE Press. Retrieved Jan. 6, 2004b from <http://www.blognija.com/DDGDD04.doc>.

Hine, Christine (June, 2001). Web pages, authors and audiences: The meaning of a mouse click. *Information, Communication & Society*, 4(2), 182-198

Hogan, Rebecca S. (1991). Endangered Autobiographies: Diaries as a Feminine Form. *Prose Studies*, 14(2), 95-107

Huff, Cynthia A. (1996). Textual boundaries: Space in Nineteenth-century women's manuscript dairies. In Suzanne L. Bunkers & Cynthia A. Huff (Eds.), *Inscribing the Daily: Critical Essays on Women's Diaries* (pp. 123-138). Amherst: University of Massachusetts Press.

Huffaker, David (Jan., 2004). Spinning yarns around the digital fire: Storytelling and dialogue among youth on the Internet. *First Monday*, 9(1). Available from http://www.firstmonday.dk/issues/issue9_1/huffaker/.

Jelinek, Estelle C. (1980). Introduction: Women's autobiography and the male tradition. In Estelle C. Jelinek (Ed.), *Women's Autobiography: Essays in Criticism* (pp. 1-20). Bloomington IN: Indiana University Press.

Kitzmann, Andreas (2004). *Saved from Oblivion: Documenting the Daily from Diaries to Web Cams*. New York: Peter Lang.

- Langellier, Kristin M. (1998). Voiceless bodies, bodiless voices: The future of personal narrative performance. In Sharon J. Dailey (Ed.), *The Future of Performance Studies: Visions and Revisions* (pp. 207-213). Annandale VA: National Communication Association.
- Langellier, Kristin M. & Peterson, Eric E. (2004). *Storytelling in Daily Life: Performing Narrative*. Philadelphia: Temple University Press.
- LaPin, Gianna (1998). "Pick a Gender and Get Back to Us": How cyberspace affects who we are. *Fragment.nl*. Retrieved Aug. 30, 2004 from http://www.fragment.nl/mirror/various/LaPin_G.1998.Pick_a_gender_and_get_back_to_us.htm.
- Laurel, Brenda (2001). Computers as theatre. In David Trend (Ed.), *Reading Digital Culture* (pp. 109-114). Malden MA: Blackwell.
- Lejeune, Philippe (Winter 2001). How do diaries end? *Biography: An Interdisciplinary Quarterly*, 24(1), 99-112
- Lenhart, Amanda, Rainie, Lee, & Lewis, Oliver (June 20, 2001). Teenage Life Online: The rise of the instant-message generation and the Internet's impact on friendship and family relationships. *PEW Internet & American Life Project*. Retrieved Nov. 27, 2002 from http://www.pewinternet.org/reports/pdfs/PIP_Teens_Report.pdf.
- Livingstone, Sonia & Bober, Magdalena (Oct., 2003). *UK Children Go Online: Listening to young people's experiences* London: Economic & Social Research Council.
- Livingstone, Sonia & Bober, Magdalena (July, 2004). *UK Children Go Online: Surveying the experiences of young people and their parents* London: Economic & Social Research Council.
- McLaughlin, Margaret L., Goldberg, Steven B., Ellison, Nicole B., & Lucas, Jason (1999). Measuring internet audiences: Patrons of an on-line art museum. In Steven G. Jones (Ed.), *Doing Internet Research* (pp. 163-178). Thousand Oaks CA: Sage Publications.
- Mcneill, Laurie (Winter 2003). Teaching an Old Genre New Tricks: The Diary on the Internet. *Biography: An Interdisciplinary Quarterly*, 26(1), 24-48
- Ong, Walter (1982). *Orality and Literacy: The Technologizing of the Word*.
- Orlowski, Andrew (May 30, 2003). Most bloggers 'are teenage girls' - survey. *The Register*. Retrieved May 30, 2003 from <http://www.theregister.co.uk/content/6/30954.html>.
- Reid, Elizabeth M. (1991). *Electropolis: Communication and community on internet relay chat*. Honors Thesis, Department of History, University of Melbourne. Retrieved from <http://www.nicoladoering.de/Hogrefe/reid91.htm>.

Reid, Elizabeth M. (Jan., 1994). *Cultural Formation in Text-Based Virtual Realities*. Master's Thesis, Cultural Studies Program, Department of English, University of Melbourne. Retrieved from <http://www.aluluei.com/>.

Rhodes, John S. (2002). In the trenches with a weblog pioneer: An interview with the force behind Eatonweb, Brigitte F. Eaton. In John Rodzvilla (Ed.), *We've Got Blog: How Weblogs are Changing Our Culture* (pp. 99-103). Cambridge MA: Perseus Publishing.

Stauffer, Todd (2002). *Blog On: The Essential Guide to Building Dynamic Weblogs*. New York: McGraw-Hill/Osborne.

Steinberg, Laurence D. (2002). *Adolescence*. (6th ed.) New York: McGraw-Hill College.

Stern, Susannah R. (2004). Expression of identity online: Prominent features and gender differences in adolescents' WWW home pages. *Journal of Broadcasting & Electronic Media*

Turner, Victor (1982). *From Ritual to Theatre: The Human Seriousness of Play*. New York: PAJ Publications.

Walker, Jill (June 28, 2003). final version of weblog definition. *jill/tx*. Retrieved Aug. 30, 2004 from http://huminf.uib.no/~jill/archives/blog_theorising/final_version_of_weblog_definition.html.

Wei, Carolyn (2004). Formation of Norms in a Blog Community. In Laura J. Gurak, Smiljana Antonijevic, Laurie Johnson, Clancy Ratliff, & Jessica Reyman (Eds.), *Into the Blogosphere: Rhetoric, Community, and Culture of Weblogs*. Minneapolis: University of Minnesota. Retrieved July 2, 2004 from http://blog.lib.umn.edu/blogosphere/formation_of_norms.html.

Winer, Dave (2002). The history of weblogs. *Weblogs.com*. Retrieved Aug. 30, 2004 from <http://newhome.weblogs.com/historyOfWeblogs>.

Yordon, Judy E. (1999). *Roles in Interpretation*. (4th ed.) New York: McGraw-Hill College.